

V.P. & R.P.T.P.SCIENCE COLLEGE PHYSICS DEPARTMENT

VALLABH VIDYANAGR

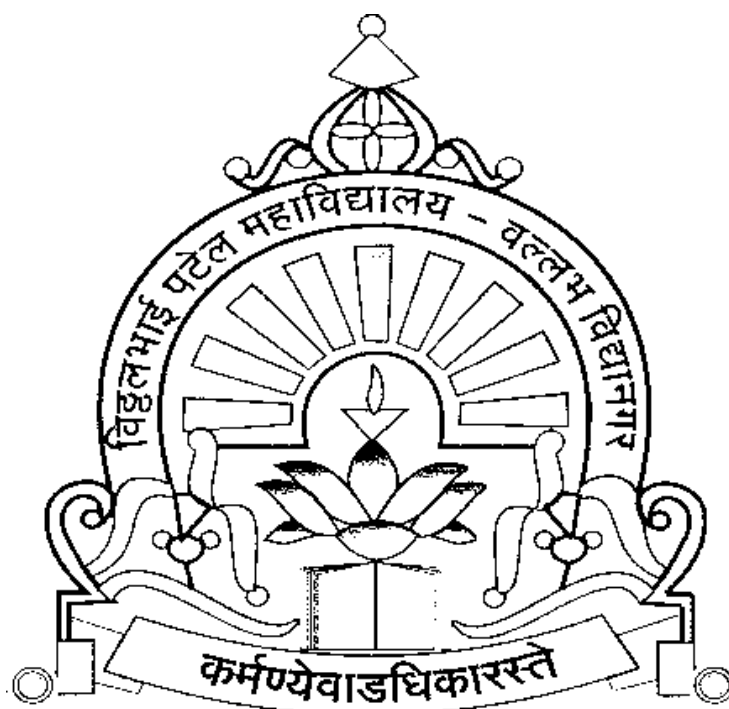

5TH SEMESTER B.Sc. PHYSICS US05CPHY07/08/09 PRACTICAL VIVA VOCE BOOK

JUNE 2017

**V.P. & R.P.T.P. SCIENCE COLLEGE
VALLABH VIDYANAGAR**

B. Sc. Semester-5

Physics Practical -VIVA-VOCE

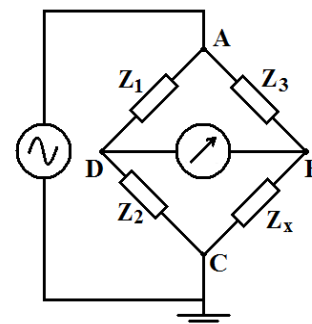
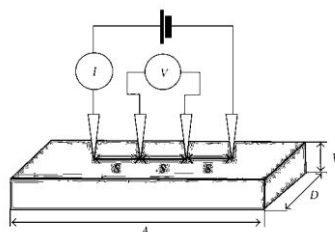
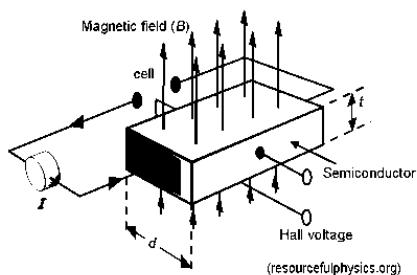

No.	Experiment	Course	Page No.
1	Searl's Goniometer-I (Fixed Distance)	PHY09	39
2	Hall Effect-I (Constant Mag. Field)	PHY07	39
3	Logic Gates	PHY08	40
4	Astable Multivibrator	PHY08	41
5	Solar cell	PHY09	43
6	Capacitance by De Sauty Method	PHY07	45
7	Michelson Interferometer-I(λ Measurements)	PHY09	46
8	Four Probe Method	PHY07	47
9	Monostable Multivibrator	PHY08	41
10	Class A Amplifier	PHY08	49
11	Phase angle by CRO	PHY07	52
12	Operational Amplifier-I (Inv.& Non Inv.)	PHY08	54
13	Constant of B.G.	PHY07	55
14	Low Resistance by B.G.	PHY07	55
15	Frequency Response of Opamp.	PHY08	54
16	Amplitude Modulation-Demodulation	PHY08	56
17	Study of flip flops.	PHY08	57
18	Diagonalization of Matrix: Jacobi's Method	PHY09	59

1	Searl's Goniometer	PHY08
---	---------------------------	--------------

What do you mean by a coaxial system of lenses?

When a number of lenses having a common principal axis are used, then this combination is called a coaxial system of lenses.

Define: Optical System.

A collection of mirror, lenses, prism and other devices, placed in some specified configuration, which reflect, refract, disperse absorb, polarize or otherwise act on light.

What do you understand by cardinal points of a coaxial system?

The six points of an optical viz. two principal points, two focal points and two nodal points are called the cardinal points.

What are principal points?

The principal points are a pair of conjugate principal axis for which linear, transverse, magnification is unity and positive.

Define focal points.

The points to which rays that are initially parallel to the axis of lens mirror or other optical system are converged or from which they appear to diverge. **OR**

First, focal point is an object point on the principal axis of an optical system for which the image points lies at infinity.

The second focal is an image point on the principal axis of an optical system for which the object point system for which the object points lies at infinity.

What are nodal points?

Nodal points are a pair of conjugate points having unit positive angular magnification. **OR**

A pair of points on the axis of an optical system such that an incident ray passing through one of them / results in parallel emergent ray passing **through the other.**

How will you mark the position of cardinal points of the lens system or optical diagram?

First of all, the positions of nodal points or principal points (They coincide as medium on both side is air.) are marked with respect to the corresponding lens. Now the focal points are marked at distances equal to the combined focal lengths from the corresponding principal points.

What is the importance of these points?

The points are of great importance in the image formation by a coaxial lens system because the procedure is greatly simplified.

Refer OPTICS Units of S.Y. B.Sc.

2	Hall Effect	PHY07
---	--------------------	--------------

Define Hall Effect.

The **Hall effect** is the production of a voltage difference (the **Hall voltage**) across an electrical conductor, transverse to an electric current in the conductor and a magnetic field perpendicular to the current. It was discovered by Edwin Hall in 1879.

The Hall coefficient is defined as the ratio of the induced electric field to the product of the current density and the applied magnetic field. It is a characteristic of the material from which the conductor

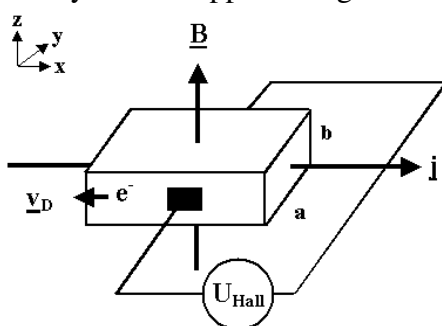

is made, since its value depends on the type, number, and properties of the charge carriers that constitute the current.

Explain the situation with the help of diagram.

If current passes along X-direction of specimen (I_x) and the magnetic field be applied in Z-direction (B_z) then a potential difference developed in Y-direction (V_y). This voltage is known as Hall voltage.

On what factors does the Hall voltage depends?

The Hall voltage depends on ; Applied magnetic field and amount of current passing through the sample.

On what does the direction of the Hall voltage depends?

The direction of the Hall voltage depends upon the nature of the charge carriers.

What do you mean by a hole?

When an electron moves from the valance band into the conduction band of a semiconductor, it leaves behind an unfilled state. The absence of an electron in the valance band is called positive hole.

Define Hall Coefficient. Give its practical unit.

Hall coefficient is numerically equal to Hall field produced by unit current density and unit field. It is measured in Columbus/cm².

How does the value of Hall coefficient change with the current through the specimen?

Hall coefficient decreases with the increase in current.

In which direction do you measure the value of b, used in formula for R_H?

The value of breadth of the crystal (b) is measure along Z-direction.

Define mobility of a charger carrier.

Mobility (μ) is defined as the drift velocity acquired in a unit electric field.

Define electric conductivity.

The electric conductivity (σ) is defined as the reciprocal of resistivity.

$$I_z = \sigma E_x$$

Is there any relation between mobility and electrical conductivity?

Yes, the relation between mobility and electric conductivity = R_H σ, where

$$R_H = \frac{E_y}{I_x B_z}$$

Mention the importance of this experiment.

The study of Hall effect is important because:

- The sign of the current carrying charge is determined.
- The number of charge carriers per unit volume can be investigated from Hall-coefficient R_H.
- The mobility is measured directly.
- It can be used to determine electronic structure of the substance. i.e. they are metals, semiconductors or insulators. (If n < 10¹⁷ insulators, 10¹⁷ ≤ n ≤ 10²⁰ semiconductor, n ≥ 10²² metallic.)
- The knowledge of Hall voltage developed enables us to measure high unknown magnetic field provided we know Hall constants for the slab used for it.
- It gives the concept of negative mass.

3	Logic Gates	PHY08
----------	--------------------	--------------

Define Logic Gate.

The circuits which use diodes and transistors to perform switching action are known as logic gates. The logic gates are used in digital system like computer, data-processing control or digital communication system.

There are four logic circuit commonly uses: AND gate, OR gate, NOT gate and FLIP FLOP.

Define AND gate and its truth table.

The gate circuit which provides an HIGH output when all the inputs are simultaneously HIGH is known as AND gate.

Define OR gate and its truth table.

The gate circuit which provides HIGH output when the HIGH signal is applied to any one to all the inputs is known as OR gate.

Define NOT gate and its truth table.

We may have gate circuit which provides the HIGH output when the input signal applied is LOW or Vice Versa, Such a circuit is known as NOT gate.

Define a NOR gate and obtain its truth table.

If a NOT circuit follows the OR gate, the combined circuit will act as NOT-OR circuit. If we combine the two words the circuit is called as NOR circuit.

Define a NAND gate and obtain its truth table.

If a NOT circuit follows the AND gate, the combined circuit will work as NOT-AND circuit. If we combine the two words the circuit is called as NAND circuit.

State and explain DeMorgan's laws.

State various applications of gate circuits.

Draw the logic circuits and prepare truth table for the following Boolean expressions.

1. $Y = \overline{A + B}$

2. $Y = \overline{A} \cdot \overline{B}$

3. $Y = \overline{A \cdot B}$

4. $Y = \overline{A} + \overline{B}$

4 & 9	Astable and Monostable Multivibrator	PHY08
------------------	---	--------------

What is a Multivibrator Circuit?

An electronic circuit that generates non-sinusoidal waves (e.g. square, rectangular or saw tooth wave) is known as multivibrator.

An electronic oscillator consisting of two active devices, usually interconnected in an electrical network is called a multivibrator.

What is the purpose of this device?

The purpose of this device is to generate a continuous square wave. It stores information in binary form in a logic circuit.

How is it achieved?

It is achieved by applying a portion of the output voltage or current of each active device to the input of the other with the appropriate magnitude and polarity, so that the devices are conducting alternately for controllable periods.

What are different forms of multivibrator?

There are three different forms of multivibrator: (i) Free running multivibrator

(ii) Single shot multivibrator (iii) Bistable multivibrator

What is a Astable multivibrator or free running multivibrator?

A free multivibrator is that which produces pulses and extended waveform independently without any external synchronizing voltage pulse.

What is monostable multivibrator or single shot multivibrator?

A single shot multivibrator is that which requires one driving pulse for the production of each cycle of wave form.

What is flip-flop multivibrator or bistable multivibrator?

A bistable multivibrator is that which requires two driving pulse for the production of each cycle of wave form.

What are non-sinusoidal waves?

The wave which does not have the curve as that of a sine curve is called non-sinusoidal waves. e.g. Square, rectangular, saw tooth waves are non-sinusoidal waves.

Among the non-sinusoidal oscillators, the square wave generator is very important.

Square waves are required for testing video amplifiers (Pulse amplifiers). Repetitive pulses find applications in radar & in triggering and many digital circuits.

What is delay time?

The Total time required to the collector current reaches to rise 10% of its maximum value after applying input single is known as delay time.

ASTABLE MULTIVIBRATOR

Working: Among the non-sinusoidal oscillators, the square wave generator is very important. Square waves are required for testing video amplifiers (Pulse amplifiers). Repetitive pulses find applications in radar and in triggering and many digital circuits.

An astable (or free running) multivibrator generates square waves. It is a basic collector coupled transistors multivibrator. It is essentially a two-stage RC-coupled amplifier with the output of the first stage coupled to the input of the second stage, and the output of the second stage is coupled to the input of the first stage. Since the phase of a signal is reversed when amplified by a single stage of the CE amplifier it comes back to its original phase when passed through two stages. Thus the signal feed-back to the base of either transistor is in the same phase as the original signal at its input. It amounts to positive feedback. In a multivibrator (also called relaxation Oscillator), the

amount of feedback is very large. So large, that the transistors are driven between cut-off and saturation region almost instantaneously.

A transistor remains in either saturation or cut-off for a period determined by the time constant of the elements in the base circuit.

Monostable Multivibrators

Multivibrators are Sequential regenerative circuits either synchronous or asynchronous that are used extensively in timing applications. Multivibrators produce an output wave shape of a symmetrical or asymmetrical square wave and are the most commonly used of all the square wave generators. Multivibrators belong to a family of oscillators commonly called "**Relaxation Oscillators**".

Generally speaking, discrete multivibrators consist of a two transistor cross coupled switching circuit designed so that one or more of its outputs are fed back as an input to the other transistor with a resistor and capacitor (RC) network connected across them to produce the feedback tank circuit. Multivibrators have two different electrical states, an output "HIGH" state and an output "LOW" state giving them either a stable or quasi-stable state depending upon the type of multivibrator. One such type of a two state pulse generator configuration are called **Monostable Multivibrators**.

Monostable Multivibrator Circuit

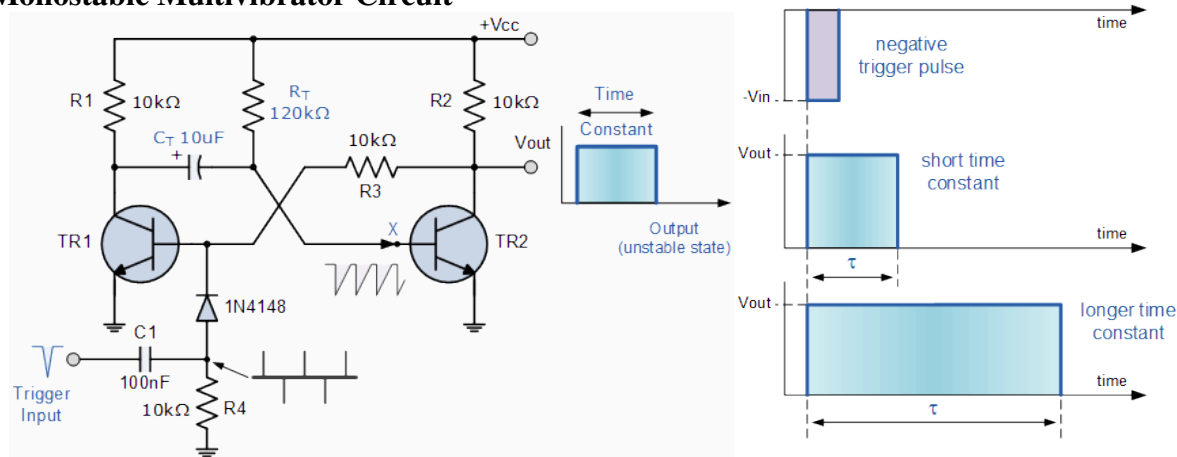

The basic collector-coupled **Monostable Multivibrator** circuit and its associated waveforms are shown above. When power is firstly applied, the base of transistor TR2 is connected to Vcc via the biasing resistor, R_T thereby turning the transistor "fully-ON" and into saturation and at the same time turning TR1 "OFF" in the process. This then represents the circuits "Stable State" with zero output. The current flowing into the saturated base terminal of TR2 will therefore be equal to $I_b = (V_{cc} - 0.7)/R_T$.

If a negative trigger pulse is now applied at the input, the fast decaying edge of the pulse will pass straight through capacitor, C_1 to the base of transistor, TR1 via the blocking diode turning it "ON". The collector of TR1 which was previously at Vcc drops quickly to below zero volts effectively giving capacitor C_T a reverse charge of $-0.7v$ across its plates. This action results in transistor TR2 now having a minus base voltage at point X holding the transistor fully "OFF". This then represents the circuits second state, the "Unstable State" with an output voltage equal to Vcc.

Timing capacitor, C_T begins to discharge this $-0.7v$ through the timing resistor R_T , attempting to charge up to the supply voltage Vcc. This negative voltage at the base of transistor TR2 begins to decrease gradually at a rate determined by the time constant of the $R_T C_T$ combination. As the base voltage of TR2 increases back up to Vcc, the transistor begins to conduct and doing so turns "OFF" again transistor TR1 which results in the monostable multivibrator automatically returning back to its original stable state awaiting a second negative trigger pulse to restart the process once again.

Monostable Multivibrators can produce a very short pulse or a much longer rectangular shaped waveform whose leading edge rises in time with the externally applied trigger pulse and whose trailing edge is dependent upon the RC time constant of the feedback components used. This RC time constant may be varied with time to produce a series of pulses which have a controlled fixed time delay in relation to the original trigger pulse as shown below.

Monostable Multivibrator Waveforms The time constant of **Monostable Multivibrators** can be changed by varying the values of the capacitor, C_T the resistor, R_T or both. Monostable multivibrators are generally used to increase the width of a pulse or to produce a time delay within a circuit as the frequency of the output signal is always the same as that for the trigger pulse input, the only difference is the pulse width.

This then gives us an equation for the time period of the circuit as:

$$\tau = 0.7RC$$

Where, R is in Ω 's and C in Farads.

We can also make monostable pulse generators using special IC's and there are already integrated circuits dedicated to this such as the 74LS121 standard one shot monostable multivibrator or the 74LS123 or the 4538B re-triggerable monostable multivibrator which can produce output pulse widths from as low as 40 nanoseconds up to 28 seconds by using only two external RC timing components with the pulse width given as: $T = 0.69RC$ in seconds.

Monostable Multivibrators Summary

Then to summarize, the **Monostable Multivibrator** circuit has only **ONE** stable state making it a "one-shot" pulse generator. When triggered by a short external trigger pulse either positive or negative. Once triggered the monostable changes state and remains in this second state for an amount of time determined by the preset time period of the RC feedback timing components used. Once this time period has passed the monostable automatically returns itself back to its original low state awaiting a second trigger pulse. Monostable multivibrators can therefore be considered as triggered pulse generators and are generally used to produce a time delay within a circuit as the frequency of the output signal is the same as that for the trigger pulse input the only difference being the pulse width. One main disadvantage of monostable multivibrators is that the time between the application of the next trigger pulse has to be greater than the preset RC time constant of the circuit to allow the capacitor time to charge and discharge.

In the next tutorial about Multivibrators, we will look at one that has **TWO** stable states that requires two trigger pulses to switched over from one stable state to the other. This type of multivibrator circuit is called a Bistable Multivibrator also known by their more common name of "Flip-flops".

5	Solar Cell	PHY08
----------	-------------------	--------------

A solar cell is an electronic device which directly converts sunlight into electricity. Light shining on

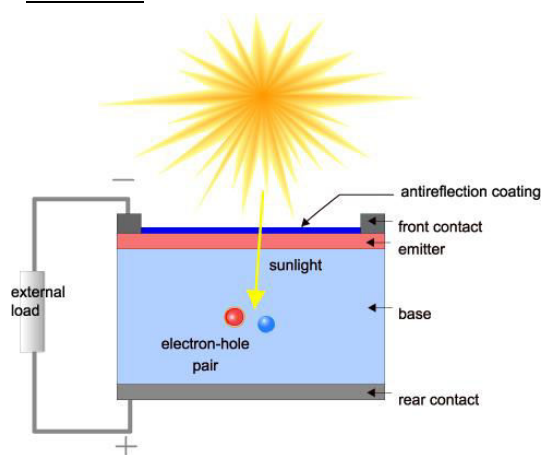

the solar cell produces both a current and a voltage to generate electric power. This process requires firstly, a material in which the absorption of light raises an electron to a higher energy state, and secondly, the movement of this higher energy electron from the solar cell into an external circuit. The electron then dissipates its energy in the external circuit and returns to the solar cell. A variety of materials and processes can potentially satisfy the requirements for photovoltaic energy conversion, but in practice nearly all photovoltaic energy conversion uses semiconductor materials in the form of a *p-n* junction.

The basic steps in the operation of a solar cell are:

1. The generation of light-generated carriers;
2. The collection of the light-generated carriers to generate a current;
3. The generation of a large voltage across the solar cell; and
4. The dissipation of power in the load and in parasitic resistances.

The generation of current in a solar cell, known as the "light-generated current", involves two key processes. The first process is the absorption of incident photons to create electron-hole pairs. Electron-

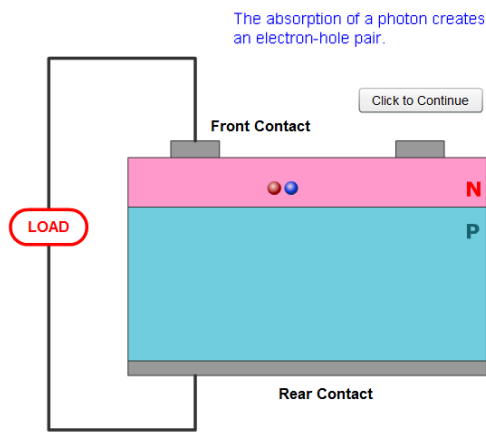

hole pairs will be generated in the solar cell provided that the incident photon has an energy greater than that of the band gap. However, electrons (in the *p*-type material), and holes (in the *n*-type material) are meta-stable and will only exist, on average, for a length of time equal to the minority carrier lifetime before they recombine. If the carrier recombines, then the light-generated electron-hole pair is lost and no current or power can be generated.

A second process, the collection of these carriers by the *p-n* junction, prevents this recombination by using a *p-n* junction to spatially separate the electron and the hole. The carriers are separated by the action of the electric field existing at the *p-n* junction. If the light-generated minority

carrier reaches the *p-n* junction, it is swept across the junction by the electric field at the junction, where it is now a majority carrier. If the emitter and base of the solar cell are connected together (i.e., if the solar cell is short-circuited), the the light-generated carriers flow through the external circuit. The ideal flow at short circuit is shown in the animation below.

The open-circuit voltage, V_{OC} , is the maximum voltage available from a solar cell, and this occurs at zero current. The open-circuit voltage corresponds to the amount of forward bias on the solar cell due to the bias of the solar cell junction with the light-generated current. The open-circuit voltage is shown on the IV curve below.

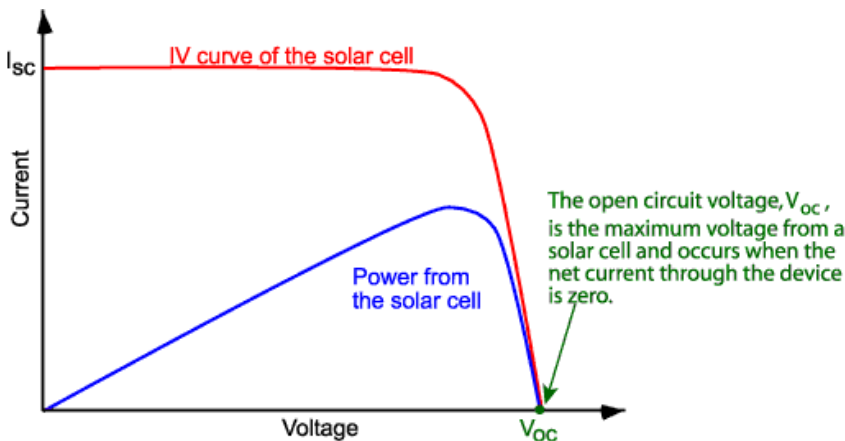

The short-circuit current is the current through the solar cell when the voltage across the solar cell is zero (i.e., when the solar cell is short circuited). Usually written as I_{SC} , the short-circuit current is shown on the IV curve below.

The short-circuit current is due to the generation and collection of light-generated carriers. For an ideal solar cell at most moderate resistive loss mechanisms, the short-circuit current and the light-generated current are identical. Therefore, the short-circuit current is the largest current which may be drawn from the solar cell.

The short-circuit current depends on a number of factors which are described below:

- **the area of the solar cell.** To remove the dependence of the solar cell area, it is more common to list the short-circuit current **density** (J_{sc} in mA/cm^2) rather than the short-circuit current;
- **the number of photons** (i.e., the power of the incident light source). I_{sc} from a solar cell is directly dependant on the light intensity as discussed in Effect of Light Intensity;
- **the spectrum of the incident light.** For most solar cell measurement, the spectrum is standardised to the AM1.5 spectrum;
- **the optical properties** (absorption and reflection) of the solar cell (discussed in Optical Losses); and
- **the collection probability** of the solar cell, which depends chiefly on the surface passivation and the minority carrier lifetime in the base.

FILL FACTOR (FF)

The short-circuit current and the open-circuit voltage are the maximum current and voltage respectively from a solar cell. However, at both of these operating points, the power from the solar cell is zero. The "fill factor", more commonly known by its abbreviation "FF", is a parameter which, in conjunction with V_{oc} and I_{sc} , determines the maximum power from a solar cell. The FF is defined as the ratio of the maximum power from the solar cell to the product of V_{oc} and I_{sc} . Graphically, the FF is a measure of the "squareness" of the solar cell and is also the area of the largest rectangle which will fit in the IV curve. The FF is most commonly determined from measurement of the IV curve and is defined as the maximum power divided by the product of $I_{sc} \cdot V_{oc}$, i.e.:

$$FF = \frac{V_{MP} I_{MP}}{V_{oc} I_{sc}}$$

EFFICIENCY:

The efficiency is the most commonly used parameter to compare the performance of one solar cell to another. Efficiency is defined as the ratio of energy output from the solar cell to input energy from the sun. In addition to reflecting the performance of the solar cell itself, the efficiency depends on the spectrum and intensity of the incident sunlight and the temperature of the solar cell. Therefore, conditions under which efficiency is measured must be carefully controlled in order to compare the performance of one device to another. Terrestrial solar cells are measured under AM1.5 conditions and at a temperature of 25°C. Solar cells intended for space use are measured under AM0 conditions. Recent top efficiency solar cell results are given in the page [Solar Cell Efficiency Results](#).

The efficiency of a solar cell is determined as the fraction of incident power which is converted to electricity and is defined as:

$$P_{max} = V_{oc} I_{sc} FF \quad \eta = \frac{V_{oc} I_{sc} FF}{P_{in}}$$

where V_{oc} is the open-circuit voltage; where I_{sc} is the short-circuit current; and where FF is the fill factor where η is the efficiency.

In a $10 \times 10 \text{ cm}^2$ cell the input power is $100 \text{ mW/cm}^2 \times 100 \text{ cm}^2 = 10 \text{ W}$.

6	Capacitance by De Sauty Method	PHY07
----------	---------------------------------------	--------------

Explain what is a capacitor?

A capacitor is basically meant to store electrons (or electrical energy), and release whenever desire. It is a device in which a large amount of charge can be stored. It consists of two metal plates placed parallel to each other at a short distance. The intermediate space is filled with some dielectric.

Define the capacity of a capacitor.

The capacity of a capacitor is numerically equal to the quantity of electricity given to the capacitor in order to maintain unit potential difference between the plates. **OR**

Capacitance of a capacitor is ratio of electric charge on it to its electric potential due to that charge. i.e.

$$C = \frac{Q \text{ Coulomb}}{V \text{ Volt}}$$

On what factors the capacity of a capacitor depends?

It depends upon the following three factors

1. Area of the plate, capacity increases with the increase of area. **2. Distance between the plates**, capacity increases when the distance between the plates is decreased. **3. Dielectric constant of the medium**, greater the value of the dielectric constant, greater the capacity.

What is the function of the dielectric in the capacitor? It increases the capacity of the capacitor.

Define dielectric constants of the materials. The ratio of the capacitance with and without the dielectric between the plates is called dielectric constant of the material used.

Which is the best dielectric and why? Mica is the best dielectric because its value is high and the dielectric strength is several kilovolts per mm i. e. its insulation does not break even if high potential difference is applied on its coating. It is used in all good standard capacitor.

Define one farad.: Capacitance of a capacitor is said to be 1 farad if one Coulomb of charge raises its potential through 1 volt.

$$1 \text{ farad} = \frac{1 \text{ Coulomb}}{1 \text{ Volt}}$$

Farad is a big unit. Smaller units generally used are:

1 micro-farad (μF) = 10^{-6} farad and 1 micro-micro-farad ($\mu\mu\text{F}$) = 10^{-12} farad

What will happen if a charged capacitor is connected with inductor?

Electric damped oscillations will take place.

What are the types of capacitors?

The type of capacitor is usually denoted by the name of the dielectric used in the capacitor such as paper, mica, ceramic, electrolytic, air, oil etc.

What kind of this bridge? AC or DC?

Explain balance condition of the bridge.

7	Michelson Interferometer-I (λ)	PHY09
---	--	--------------

What is interferometer?

Interferometer is a device used to determine the wave-length of light utilizing the phenomenon of interference of light.

Are two mirrors simply plane mirrors?

They are excellently optically plane and highly silvered polished plane mirrors.

What type of glass plates are G_1 and G_2 ? How are they mounted?

The two plates are optically flat glass plates of same thickness and of the same material. They are parallel to each other and inclined at an angle 45° with the two mirrors. G_1 is semi silvered at the face towards G_2 . G_2 is known as compensating plate.

What type of fringes is observed?

The fringes may be straight, circular parabolic etc. depending upon the path difference between two rays and the angle between two mirrors.

How do you get the circular fringes?

The circular fringes are obtained when two mirrors are exactly perpendicular to each other. (or they are enclosed in air film of uniform thickness.) The screws provided at the back of mirror M_1 are adjusted for this purpose.

Where the circular fringes are formed?

They are formed at infinity and telescope is used to receive.

What are the localized fringes?

When the two mirrors are not exactly perpendicular to each other then either straight or parabolic fringes are obtained. These are known as localized fringes.

When the mirror is moved through a distance $\pi/2$ how many fringes appear or disappear? One fringe.

What is interference? When the two waves superimpose each other, the resultant intensity is modified. This modification in the distribution of intensity in the region of superposition is called interference.

Is there any loss of energy in interference phenomenon?

No, there is only re-distribution of energy.

What are the conditions for obtaining interference of light?

The two sources should be coherent. (should vibrate in the same phase or must be a constant phase difference between them)

1. Two sources must emit waves of same wavelength and time-period. 2. The sources should be monochromatic. 3. The amplitude of interfering waves should be equal or nearly equal.

What are the interference fringes? They are alternatively bright and dark patches of light obtained in the region of superposition of two wave trains of light.

Refer Unit 3 of US01CPHY02 B.SC. SEM-1.

8	Four Probe Method	PHY07
----------	--------------------------	--------------

Define resistance and resistivity of a material.

Resistance is a physical property of the conductor based on the material of which it is made and its size and shape, including the locations where current is put in and taken out. Resistivity is a physical property only of the material of which the resistor is made."

The electrical resistance of a circuit component or device is defined as the ratio of the voltage applied to the electric current which flows through it i.e. $R=V/I$. If the resistance is constant over a considerable range of voltage, then Ohm's law, $I = V/R$, can be used to predict the behavior of the material. Although the definition above involves DC current and voltage, the same definition holds for the AC application of resistors.

The electrical resistance of a wire would be expected to be greater for a longer wire, less for a wire of larger cross sectional area, and would be expected to depend upon the material out of which the wire is made. Experimentally, the dependence upon these properties is a straightforward one for a wide range of conditions, and the resistance of a wire can be expressed as ;

$$R = \frac{\rho L}{A}$$

ρ = resistivity
 L = length
 A = cross sectional area

The factor in the resistance which takes into account the nature of the material is the resistivity. Although it is temperature dependent, it can be used at a given temperature to calculate the resistance of a wire of given geometry.

The inverse of resistivity is called conductivity. There are

contexts where the use of conductivity is more convenient. Electrical conductivity = $\sigma = 1/\rho$.

Discuss resistance –temperature relation for metals and semiconductors.

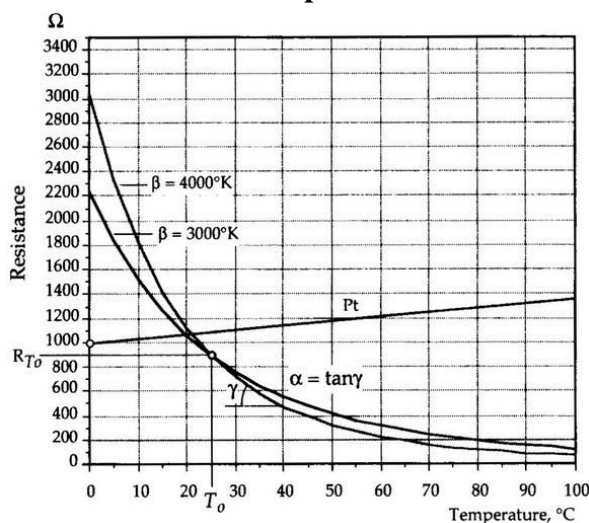

The graph shows the R-T relation for Pt metal and two semiconductor materials.

What is a four probe method?

The experimental set up consists of probe arrangement, sample, oven 0-200°C, constant current generator, oven power supply and digital panel meter (measuring voltage and current).

Four probe apparatus is one of the standard and most

widely used apparatus for the measurement of resistivity of semiconductors. This method is employed when the sample is in the form of a thin wafer, such as a thin semiconductor material deposited on a substrate. The sample is millimeter in size and having a thickness w . It consists of four probe arranged linearly in a straight line at equal distance S from each other. A constant current is passed through the two probes and the potential drop V across the middle two probes is measured. An oven is provided with a heater to heat the sample so that behavior of the sample is studied with increase in temperature. The figure shows the arrangements of four probes that measure voltage (V) and supply current (A) to the surface of the crystal.

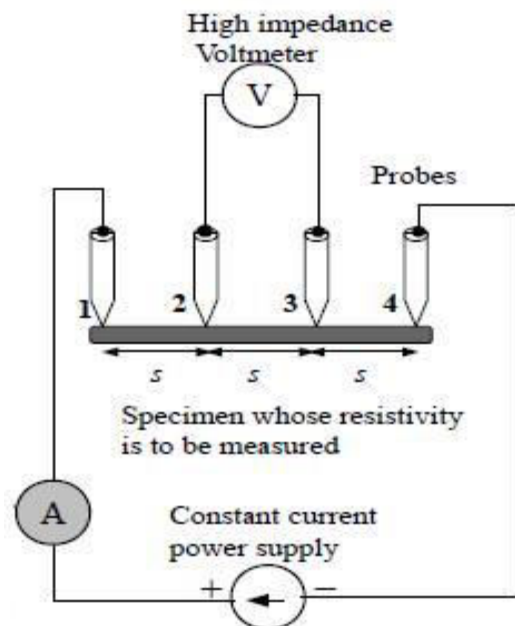

THEORY

At a constant temperature, the resistance, R of a conductor is proportional to its length L and inversely proportional to its area of cross section A .

$$R = \rho \frac{L}{A} \quad (1)$$

Where ρ is the resistivity of the conductor and its unit is ohmmeter.

A semiconductor has electrical conductivity intermediate in magnitude between that of a conductor and insulator. Semiconductor differs from metals in their characteristic property of decreasing electrical resistivity with increasing temperature.

According to band theory, the energy levels of semiconductors can be grouped into two bands, valence band and the conduction band. In the presence of an external electric field it is electrons in the valence band that can move freely, thereby responsible for the electrical conductivity of semiconductors. In case of intrinsic semiconductors, the Fermi level lies in between the conduction band minimum and valence band maximum. Since conduction band lies above the Fermi level at $0K$, when no thermal excitations are available, the conduction band remains unoccupied. So conduction is not possible at $0K$, and resistance is infinite. As temperature increases, the occupancy of conduction band goes up, thereby resulting in decrease of electrical resistivity of semiconductor.

Resistivity of semiconductor by four probe method

1. The resistivity of material is uniform in the area of measurement.
2. If there is a minority carrier injection into the semiconductor by the current-carrying electrodes most of the carriers recombine near electrodes so that their effect on conductivity is negligible.
3. The surface on which the probes rest is flat with no surface leakage.
4. The four probes used for resistivity measurement contact surface at points that lie in a straight line.
5. The diameter of the contact between metallic probes and the semiconductor should be small compared to the distance between the probes.
6. The boundary between the current carrying electrodes and the bulk material is hemispherical and small in diameter.
7. The surface of semiconductor material may be either conducting and non-conducting. A conducting boundary is one on which material of much lower resistivity than semiconductor has been plated. A non-conducting boundary is produced when the surface of the semiconductor is in contact with insulator.

Fig: 2 show the resistivity probes on a die of material. If the side boundaries are adequately far from the probes, the die may be considered to be identical to a slice. For this case of a slice of thickness w and the resistivity is computed as

$$\rho = \frac{\rho_0}{f\left(\frac{w}{s}\right)} \quad (2)$$

The function, $f(w/S)$ is a divisor for computing resistivity which depends on the value of w and S . We assume that the size of the metal tip is infinitesimal and sample thickness is greater than the distance between the probes,

$$\rho_0 = \frac{V}{I} \times 2\pi S \quad (3)$$

Where V – the potential difference between inner probes in volts.

I – Current through the outer pair of probes in ampere.

S – Spacing between the probes in meter.

Temperature dependence of resistivity of semiconductor

Total electrical conductivity of a semiconductor is the sum of the conductivities of the valence band and conduction band carriers. Resistivity is the reciprocal of conductivity and its temperature dependence is given by

$$\rho = A \exp \frac{E_g}{2KT} \quad (4)$$

Where E_g – band gap of the material

T – Temperature in kelvin

K – Boltzmann constant, $K = 8.6 \times 10^{-5} \text{ eV/K}$

The resistivity of a semiconductor rises exponentially on decreasing the temperature.

Applications

1. Remote sensing areas
2. Resistance thermometers
3. Induction hardening process
4. Accurate geometry factor estimation
5. Characterization of fuel cells bipolar plates

10	Class A Amplifier	PHY08
-----------	--------------------------	--------------

1. What is an amplifier? 2. State various types of amplifiers. 3. What do you mean by class A operation of amplifier? 4. Which is the other mode of operation of amplifier? Explain them.

Define gain of an amplifier. 5. Explain variations of Gain with frequency. 6. What are lower and upper cut-off (i.e., half-power) frequencies of an amplifier? Explain. 7. What is bandwidth of an amplifier?

State its significance.

Class A Amplifiers are the most common type of amplifier class due mainly to their simple design. Class A, literally means “the best class” of amplifier due mainly to their low signal distortion levels and are probably the best sounding of all the amplifier classes mentioned here. The class A amplifier has the highest linearity over the other amplifier classes and as such operates in the linear portion of the characteristics curve.

Generally class A amplifiers use the same single transistor (Bipolar, FET, IGBT, etc) connected in a common emitter configuration for both halves of the waveform with the transistor always having current flowing through it, even if it has no base signal. This means that the output stage whether using a Bipolar, MOSFET or IGBT device, is never driven fully into its cut-off or saturation regions but instead has a base biasing Q-point in the middle of its load line. Then the transistor never turns “OFF” which is one of its main disadvantages.

Class A Amplifier

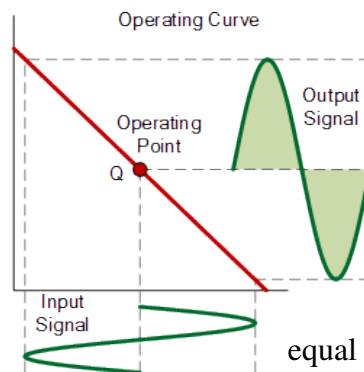
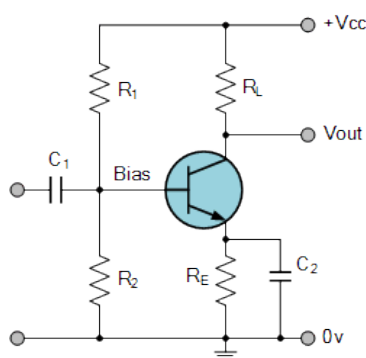

To achieve high linearity and gain, the output stage of a class A amplifier is biased “ON” (conducting) all the time. Then for an amplifier to be classified as “Class A” the zero signal idle current in the output

stage must be equal to or greater than the maximum load current (usually a loudspeaker) required to

produce the largest output signal.

As a class A amplifier operates in the linear portion of its characteristic curves, the single output device conducts through a full 360 degrees of the output waveform. Then the class A amplifier is equivalent to a current source.

Since a class A amplifier operates in the linear region, the transistors base (or gate) DC biasing voltage should be chosen properly to ensure correct operation and low distortion. However, as the output device is “ON” at all times, it is constantly carrying current, which represents a continuous loss of power in the amplifier.

Due to this continuous loss of power class A amplifiers create tremendous amounts of heat adding to their very low efficiency at around 30%, making them impractical for high-power applications.

Also due to the high idling current of the amplifier, the power supply must be sized accordingly and be well filtered to avoid any amplifier hum and noise. Therefore, due to the low efficiency and overheating problems of Class A amplifiers, more efficient amplifier classes have been developed.

Class B amplifiers were invented as a solution to the efficiency and heating problems associated with the previous class A amplifier. The basic class B amplifier uses two complimentary transistors either bipolar or FET for each half of the waveform with its output stage configured in a “push-pull” type arrangement, so that each transistor device amplifies only half of the output waveform. In the class B amplifier, there is no DC base bias current as its quiescent current is zero, so that the dc power is small and therefore its efficiency is much higher than that of the class A amplifier. However, the price paid for the improvement in the efficiency is in the linearity of the switching device.

Class B Amplifier

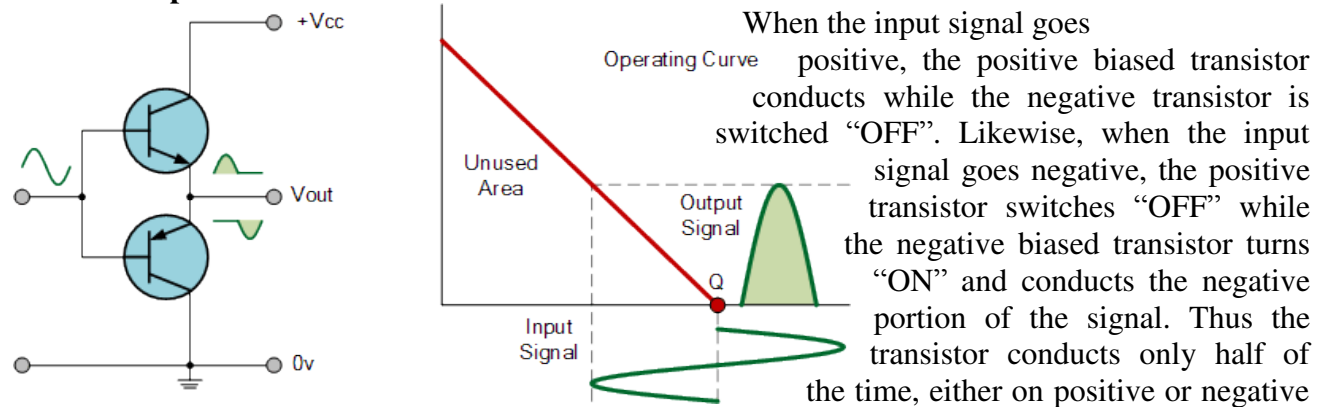

half cycle of the input signal.

Then we can see that each transistor device of the class B amplifier only conducts through one half or 180 degrees of the output waveform in strict time alternation, but as the output stage has devices for both halves of the signal waveform the two halves are combined together to produce the full linear output waveform.

This push-pull design of amplifier is obviously more efficient than Class A, at about 50%, but the problem with the class B amplifier design is that it can create distortion at the zero-crossing point of the waveform due to the transistors dead band of input base voltages from -0.7V to +0.7.

We remember from the [Transistor](#) tutorial that it takes a base-emitter voltage of about 0.7 volts to get a bipolar transistor to start conducting. Then in a class B amplifier, the output transistor is not “biased” to an “ON” state of operation until this voltage is exceeded.

This means that the the part of the waveform which falls within this 0.7 volt window will not be reproduced accurately making the class B amplifier unsuitable for precision audio amplifier applications.

To overcome this zero-crossing distortion (also known as [Crossover Distortion](#)) class AB amplifiers were developed.

Class AB Amplifier

As its name suggests, the **Class AB Amplifier** is a combination of the “Class A” and the “Class B” type amplifiers we have looked at above. The AB classification of amplifier is currently one of the most common used types of audio power amplifier design. The class AB amplifier is a variation of a class B amplifier as described above, except that both devices are allowed to conduct at the same time around the waveforms crossover point eliminating the crossover distortion problems of the previous class B amplifier.

The two transistors have a very small bias voltage, typically at 5 to 10% of the quiescent current to bias the transistors just above its cut-off point. Then the conducting device, either bipolar or FET, will be “ON” for more than one half cycle, but much less than one full cycle of the input signal. Therefore, in a class AB amplifier design each of the push-pull transistors is conducting for slightly more than the half cycle of conduction in class B, but much less than the full cycle of conduction of class A.

In other words, the conduction angle of a class AB amplifier is somewhere between 180° and 360° depending upon the chosen bias point as shown.

Class AB Amplifier

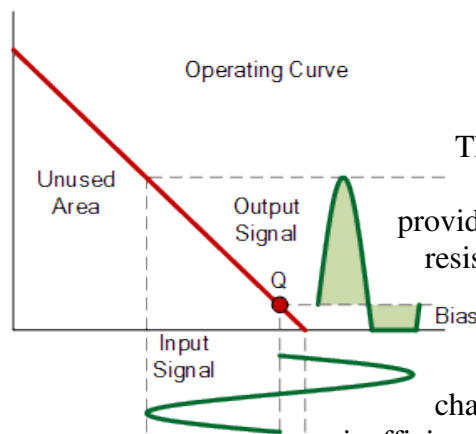
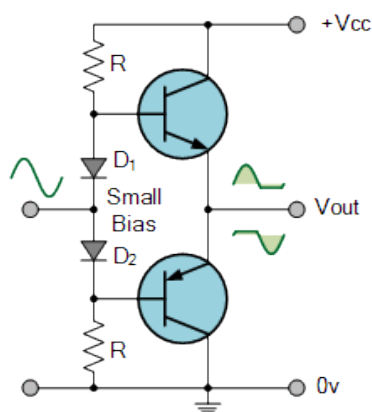

The advantage of this small bias voltage, provided by series diodes or resistors, is that the crossover distortion created by the class B amplifier characteristics is overcome, inefficiencies of the class A

without the

amplifier design. So the class AB amplifier is a good compromise between class A and class B in terms of efficiency and linearity, with conversion efficiencies reaching about 50% to 60%.

The **Class C Amplifier** design has the greatest efficiency but the poorest linearity of the classes of amplifiers mentioned here. The previous classes, A, B and AB are considered linear amplifiers, as the output signals amplitude and phase are linearly related to the input signals amplitude and phase. However, the class C amplifier is heavily biased so that the output current is zero for more than one half of an input sinusoidal signal cycle with the transistor idling at its cut-off point. In other words, the conduction angle for the transistor is significantly less than 180 degrees, and is generally around the 90 degrees area. While this form of transistor biasing gives a much improved efficiency of around 80% to the amplifier, it introduces a very heavy distortion of the output signal. Therefore, class C amplifiers are not suitable for use as audio amplifiers.

Class C Amplifier Due to its heavy audio distortion, class C amplifiers are commonly used in high frequency sine wave oscillators and certain types of radio frequency amplifiers, where the pulses of current produced at the amplifiers output be converted to complete sine waves of a particular frequency by the use of LC resonant circuits in its collector circuit.

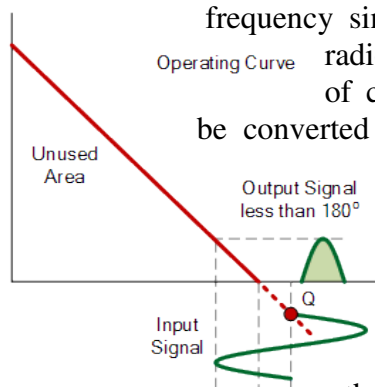
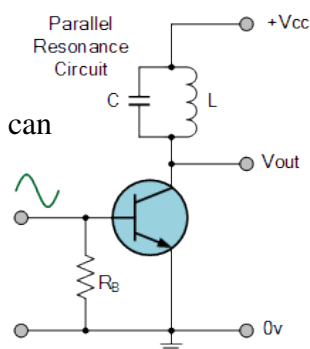

Amplifier Classes Summary

Then we have seen

that the quiescent DC operating point (Q-point) of an amplifier determines the amplifier classification. By setting the position of the Q-point at half way on the load line of the amplifiers characteristics curve, the amplifier will operate as a class A amplifier. By moving the Q-point lower down the load line changes the amplifier into a class AB, B or C amplifier.

Then the class of operation of the amplifier with regards to its DC operating point can be given as:

Amplifier Classes and Efficiency

As well as audio amplifiers there are a number of high efficiency **Amplifier Classes** relating to switching amplifier designs that use different switching techniques to reduce power loss and increase efficiency. Some amplifier class designs listed below use RLC resonators or multiple power-supply voltages to reduce power loss, or are digital DSP (digital signal processing) type amplifiers which use pulse width modulation (PWM) switching techniques.

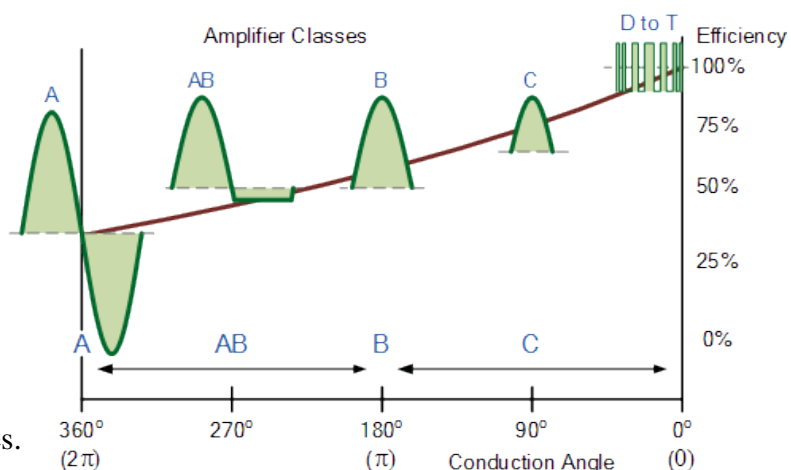

In class A, biasing a single active device (generally a transistor) allows it to operate in its linear conduction region during the entire input cycle. “Biasing” refers to the limiting of an input signal to a certain voltage or current range. “Linear” conduction means that changes in the amplified output of the circuit are exactly proportional to changes in the input.

Two active devices exist in class B amplifiers. The input waveform is split. One active device conducts during half of an input cycle, the other during the other half. The two halves are reassembled at the amplifier’s output. At times, class B amplifiers called “push-pull,” because the outputs of the active devices have a 180° phase relationship.

Class AB amplifiers resemble class Bs, except their active devices are biased so both conduct during an overlapping portion of each input cycle. This sacrifices a certain amount of potential gain for better linearity (i.e., there’s a smoother transition at the crossover point of the output signal). Class AB sacrifices some of that efficiency for lower distortion.

Analog amplifiers are cataloged by how much current flows during each wave cycle. Measured in degrees, 360° means current flows 100% of the time. The more current, the more inefficient and the more heat generated.

Class A The amplifier conducts current throughout the entire cycle (360°). The Class A design is the most inefficient and is used in low-power applications as well as in very high-end stereo. Such devices may be as little as 15% efficient, with 85% of the energy wasted as heat.

Class B The current flows only 180° for half the cycle, or two transistors can be used in a push-pull fashion, each one operating for 180°. More efficient than Class A, it is typically used in low-end products.

Class AB Combines Class A and B and current flows for 180° to 200°. Class AB designs are the most widely used for audio applications. Class AB amplifiers are typically about 50% efficient.

Class C Operating for less than half of one wave cycle (100° to 150°), Class C amplifiers are the most efficient, but not used for audio applications because of their excessive distortion.

Class G A variation of the Class AB design that improves efficiency by switching to different fixed voltages as the signal approaches them.

Class H An enhancement of the Class G amplifier in which the power supply voltage is modulated and always slightly higher than the input signal.



Current Flowing The red indicates how much of the time current is flowing through one wave cycle.

11	Phase angle by CRO	PHY07
-----------	---------------------------	--------------

What is CRO? The instrument used to display the wave form of an AC single is called CATHODE RAY OSCILLOSCOPE (CRO).

What is Cathode Ray Tube? Cathode ray tube is a device which converts an electrical signal into a visual one.

What is the phase angle? The different in phase between two sinusoidally varying quantities is called Phase angle.

What is phase?

The comparative representation of two alternating quantities is usually referred as phase.

What is Lissajous Figures? It is a curve in one plane drawn by a point moving under the influence of two independent, perpendicular simple harmonic motions.

OR

When two simple harmonic motions at right to each other are compounded, the path of the resultant motion is, in general, a closed curve. Such curves are called Lissajous Figures.

Why are there figure called Lissajous figure? Such curves were first obtained experimentally by Lissajous and hence is called Lissajous figure.

Define Simple Harmonic Motion? If a particle moves to and fro in a straight line in such a way that its acceleration is always directed towards a fixed point in that line and is proportional to the displacement from that point, it is said to move in simple harmonic motion

On what factor does the shape of the Lissajous figure depends? The form of the Lissajous figure depend upon (1) the ratio of frequencies (2) the amplitude (3) the relative phase of two compound motions.

What types of figure do obtain by the composition of two simple harmonic motions of equal periods, unequal amplitudes and phase difference of $0, \pi/2, \pi/4, 3\pi/4$ and π ?

The resultant path of the particle under two simple harmonic motions at the same period, one acting along the x-axis and other along the y-axis is given by

$$\frac{X^2}{a^2} + \frac{Y^2}{b^2} - \frac{2XY}{ab} \cos \phi = \sin^2 \phi$$

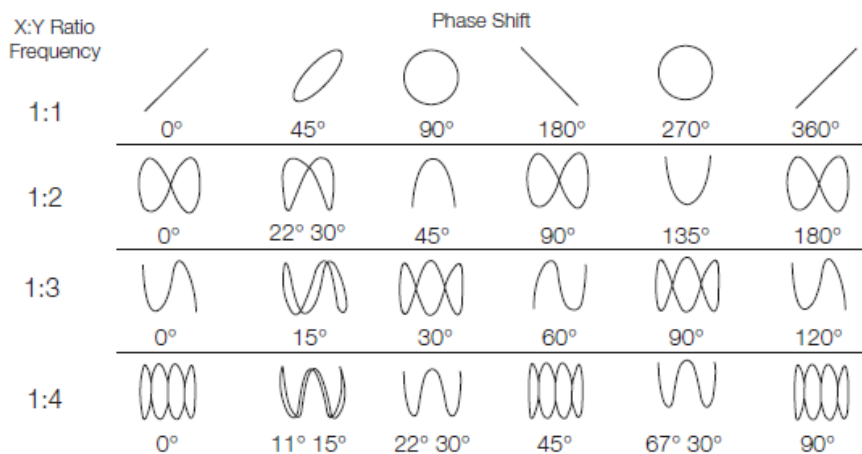
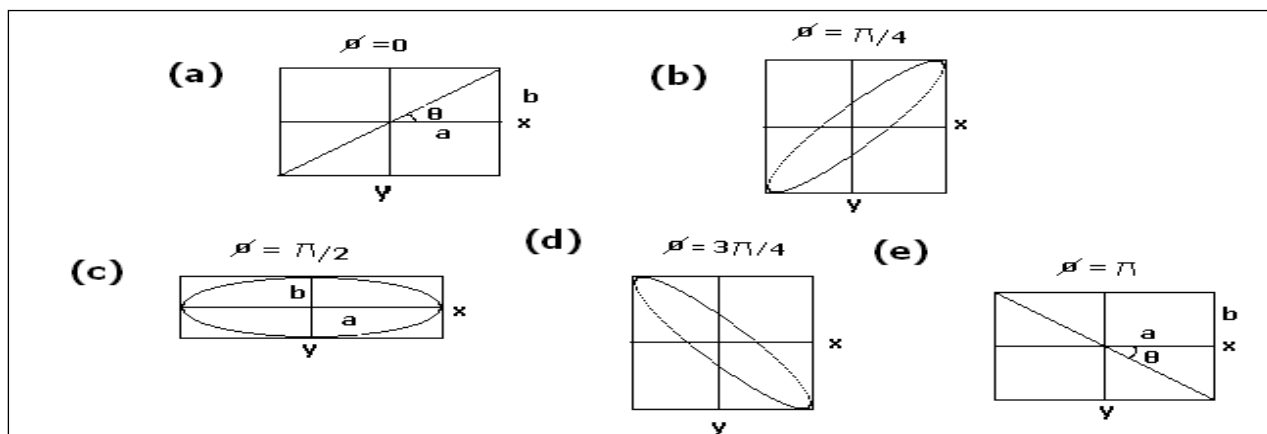

Figure 70. Lissajous patterns.

When $\phi = 0$, when two compound vibrations are in some phase, the particle describes the line shown in figure, the curve consist of two coincident straight lines passing through the origin and inclined to the X-axis at an angle θ given. Here, $\tan \theta = b/a$. In Figure (b), $\phi = \frac{\pi}{4}$, the curve is an oblique

ellipse.

In Figure (c), $\phi = \frac{\pi}{2}$, the curve is an ellipse, whose major & minor axes coincide with the co ordinate axis. In Figure (d), $\phi = \frac{3\pi}{4}$, the curve is an oblique ellipse.

In Figure (e), $\phi = \pi$, the curve again consists of two coincident straight lines passing through an origin.

How can you get a circle?

Resultant path of the particle will be circle, if phase difference is

$$\delta = \tan^{-1} \frac{1}{2\pi f R C} \quad \phi = \frac{\pi}{2} \quad \text{and } a = b.$$

What are the different methods by which Lissajous figure can be produced?

Blackburn's pendulum – a mechanical device ,Helmholtz's vibration microscope , Optical method Cathode Ray Tube – an elulrical method, Wheatstone's Kaleidophone

Which is the method of demonstrating the Lissajous figures?

A cathode ray tube provides the best method of demonstrating the production of Lissajous figures.

How do we change the phase at vibration of a S.H.M. here? The phase of vibration of a simple harmonic motion is given by

$$\delta = \tan^{-1} \frac{1}{2 \pi f R C}$$

It is therefore clear that the phase can be changed by varying either the frequency f, the resistance R or the capacitance C of the condenser. The phase is varied conventionally by changing resistance in the resistance box R, for a fixed value of f & C.

12 & 15	Operational Amplifiers	PHY08
--------------------	-------------------------------	--------------

Operational Amplifier General Conditions

- • The **Operational Amplifier**, or **Op-amp** as it is most commonly called, is an ideal amplifier with infinite Gain and Bandwidth when used in the Open-loop mode with typical DC gains of well over 100,000, or 100dB.
- • The basic Op-amp construction is of a 3-terminal device, 2-inputs and 1-output, (excluding power connections).
- • An Operational Amplifier operates from either a dual positive (+V) and an corresponding negative (-V) supply, or they can operate from a single DC supply voltage.
- • The two main laws associated with the operational amplifier are that it has an infinite input impedance, (Z_{∞}) resulting in “**No current flowing into either of its two inputs**” and zero input offset voltage “**V1 = V2**”.
- • An operational amplifier also has zero output impedance, ($Z = 0$).
- • Op-amps sense the difference between the voltage signals applied to their two input terminals and then multiply it by some pre-determined Gain, (A).
- • This Gain, (A) is often referred to as the amplifiers “Open-loop Gain”.
- • Closing the open loop by connecting a resistive or reactive component between the output and one input terminal of the op-amp greatly reduces and controls this open-loop gain.
- • Op-amps can be connected into two basic configurations, **Inverting** and **Non-inverting**.

Operational Amplifiers :

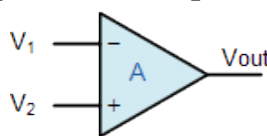

We know now that an **Operational amplifiers** is a very high gain DC differential amplifier that uses one or more external feedback networks to control its response and characteristics. We can connect external resistors or capacitors to the op-amp in a number of

Op-amp Symbol different ways to form basic “building Block” circuits such as, Inverting, Non-Inverting, Voltage Follower, Summing, Differential, Integrator and Differentiator type amplifiers.

An “ideal” or perfect Operational Amplifier is a device with certain special characteristics such as infinite open-loop gain A_o , infinite input resistance R_{in} , zero output resistance R_{out} , infinite bandwidth 0 to ∞ and zero offset (the output is exactly zero when the input is zero).

There are a very large number of operational amplifier IC's available to suit every possible application from standard bipolar, precision, high-speed, low-noise, high-voltage, etc, in either standard configuration or with internal Junction FET transistors.

Operational amplifiers are available in IC packages of either single, dual or quad op-amps within one single device. The most commonly available and used of all operational amplifiers in basic electronic kits and projects is the industry standard **μA-741**.

Op-amp Parameter and Idealised Characteristic

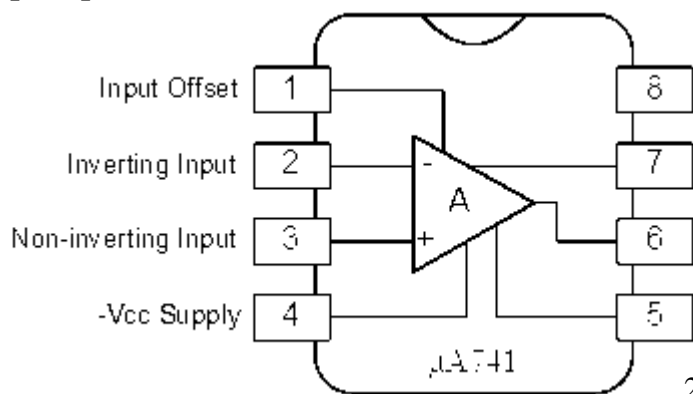

1. Open Loop Gain, (A_{vo}): Infinite – The main function of an operational amplifier is to amplify the input signal and the more open loop gain it has the better. Open-loop gain is the gain of the op-amp without positive or negative feedback and for an ideal amplifier the gain will be infinite but typical real values range from about 20,000 to 200,000.

2. Input impedance, (Z_{in})

Infinite – Input impedance is the ratio of input voltage to input current and is assumed to be infinite to prevent any current flowing from the source supply into the amplifiers input circuitry ($I_{in} = 0$). Real op-amps have input leakage currents from a few pico-amps to a few milli-amps.

3. Output impedance, (Z_{out})

Zero – The output impedance of the ideal operational amplifier is assumed to be zero acting as a perfect internal voltage source with no internal resistance so that it can supply as much current as necessary to the load. This internal resistance is effectively in series with the load thereby reducing the output voltage available to the load. Real op-amps have output-impedance in the 100-20 Ω range.

4. Bandwidth, (BW)

Infinite – An ideal operational amplifier has an infinite frequency response and can amplify any frequency signal from DC to the highest AC frequencies so it is therefore assumed to have an infinite bandwidth. With real op-amps, the bandwidth is limited by the Gain-Bandwidth product (GB), which is equal to the frequency where the amplifiers gain becomes unity.

5. Offset Voltage, (V_{io})

Zero – The amplifiers output will be zero when the voltage difference between the inverting and the non-inverting inputs is zero, the same or when both inputs are grounded. Real op-amps have some amount of output offset voltage.

From these “idealized” characteristics above, we can see that the input resistance is infinite, so **no current flows into either input terminal** (the “current rule”) and that the **differential input offset voltage is zero** (the “voltage rule”). It is important to remember these two properties as they will help us understand the workings of the **Operational Amplifier** with regards to the analysis and design of op-amp circuits.

However, real **Operational Amplifiers** such as the commonly available **uA741**, for example do not have infinite gain or bandwidth but have a typical “Open Loop Gain” which is defined as the amplifiers output amplification without any external feedback signals connected to it and for a typical operational amplifier is about 100dB at DC (zero Hz). This output gain decreases linearly with frequency down to “Unity Gain” or 1, at about 1MHz and this is shown in the following open loop gain response curve.

13 & 14	Constant of B.G. and Low Resistance	PHY07
--------------------	--	--------------

BALLISTIC GALVANOMETER

What is the construction of Ballistic Galvanometer?

What is Ballistic galvanometer? What does it measure?

Which type BG are you using a moving coil or a moving magnet type?

Why do you place a key in parallel to the galvanometer?

What is damping and on what factors does it depend?

What is the use of a tape key connected across the ballistic galvanometer?

The ballistic galvanometer is usually employed to measure the quantity of charge flowing in a given circuit due to transient current.

It consists of a coil of copper wire wound on a non-conducting frame which is suspended by a phosphor bronze strip between the poles of a strong permanent magnet horse-shoe shape magnet. In order to increase the magnetic flux in the gap, the cylindrical soft iron-core is placed within the coil. The pole pieces of the magnet are cylindrical concave in shape so that the magnetic field is radial in the narrow annular gap and is also perpendicular to the coil surface. The whole apparatus is covered in a shell to avoid disturbance from outside. Three leveling screws are provided below the base of the galvanometer. The deflection of the coil is measured by lamp and scale arrangement.

Note:- When large damping is present, the motion of the coil is non-oscillatory and the moving coil galvanometer becomes dead beat. The construction and working of such a galvanometer is different from moving coil galvanometer.

What is meant by ballistic constants of a galvanometer?

- It is a constant (K). When this constant multiplied by the first throw of the ballistic galvanometer we get charge passing through its coil.
- K depends upon the distance between scale and mirror.

What is the unit of K? The unit of constants is coulomb per mm.

Why does the coil of the ballistic galvanometer stop on pressing the tapping key?

On pressing tapping key eddy currents are induced in the coil which produces a couple in the direction which opposes the motion of the coil.

What is the difference between ballistic galvanometer and dead beat galvanometer?

What is dead beat galvanometer?

In a dead beat galvanometer, coil returns to its mean position of rest without oscillation.

Applications of Ballistic Galvanometer

To determine low resistance (less than 1Ω) and to determine high resistance (greater than $1 M\Omega$) using Ballistic Galvanometer.

Define Current sensitivity, Voltage sensitivity and Charge sensitivity.

Charge sensitivity is the linear deflection in mm produced on a scale placed 1 meter away from the mirror of the galvanometer when one micro Coulomb charge passes through it.

Current sensitivity of a galvanometer is the linear deflection in mm produced on a scale placed 1 meter away from the mirror of the galvanometer when a current of one microampere passes through it.

What is the relation between the Current sensitivity and Charge sensitivity?

The relation between current sensitivity (I_s) and charge sensitivity (Q_s) is $Q_s = \frac{2\pi}{T} I_s$.

16	Amplitude Modulation Demodulation	PHY08
----	-----------------------------------	-------

The amplitude modulation is a process in which, **amplitude of carrier signal wave is varied in accordance with the modulating or message signal by keeping the phase and frequency of the signals constant.** The carrier signal frequency would be greater than the modulating signal frequency. Amplitude modulation is first type of modulation used for transmitting messages for long distances by the mankind. The AM radio ranges in between 535 to 1705 kHz which is great. But when compared to frequency modulation, the Amplitude modulation is weak, but still it is used for transmitting messages. Bandwidth of amplitude modulation should be twice the frequency of modulating signal or message signal. If the modulating signal frequency is 10 kHz then the Amplitude modulation frequency should be around 20 kHz. In AM radio broadcasting, the modulating signal or message signal is 15 kHz. Hence the AM modulated signal which is used for broadcasting should be 30 kHz.

Advantages of Amplitude Modulation:

- Because of amplitude modulation wavelength, AM signals can propagate longer distances.
- For amplitude modulation, we use simple and low cost circuit; we don't need any special equipment and complex circuits that are used in frequency modulation.

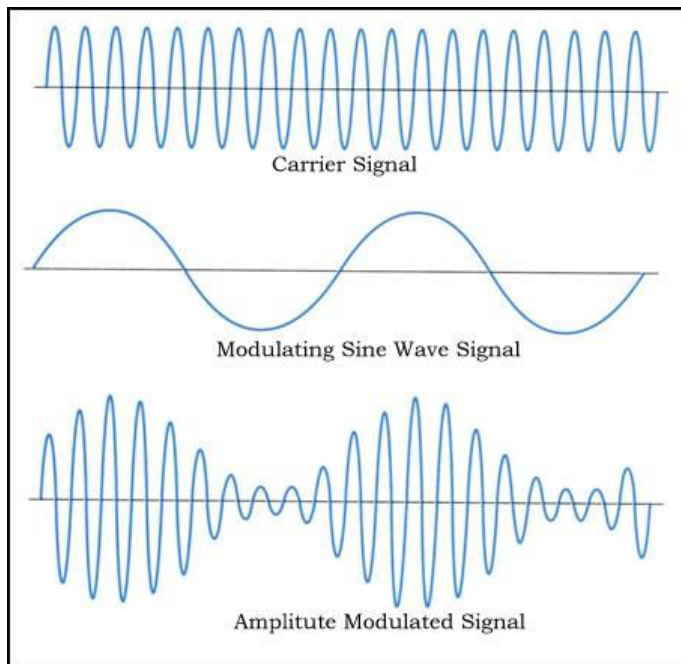

- The Amplitude modulation receiver will be wider when compared to the FM receiver. Because, atmospheric propagation is good for amplitude modulated signals.

- Bandwidths limit is also big advantage for Amplitude modulation, which doesn't have in frequency modulation.

- Transmitter and receiver are simple in Amplitude modulation. When we take a demodulation unit of AM receiver, it consists of RC filter and a diode which will demodulate the message signal or modulating signal from modulated AM signal, which is unlike in Frequency modulation.

- Zero crossing in Amplitude modulation is equidistant.

Disadvantages of Amplitude Modulation:

- Adding of noise for amplitude

modulated signal will be more when compared to frequency modulated signals. Data loss is also more in amplitude modulation due to noise addition. Demodulators cannot reproduce the exact message signal or modulating signal due to noise.

- More power is required during modulation because Amplitude modulated signal frequency should be double than modulating signal or message signal frequency. Due to this reason more power is required for amplitude modulation.
- Sidebands are also transmitted during the transmission of carrier signal. More chances of getting different signal interfaces and adding of noise is more when compared to frequency modulation. Noise addition and signal interferences are less for frequency modulation. That is why Amplitude modulation is not used for broadcasting songs or music.

Applications of Amplitude Modulation:

- Used to carry message signals in early telephone lines.
- Used to transmit Morse code using radio and other communication systems.
- Used in Navy and Aviation for communications as AM signals can travel longer distances.
- Widely used in amateur radio.

17	Flip Flops	PHY08
----	------------	-------

SR Flip-Flop

The **SR flip-flop**, also known as a *SR Latch*, can be considered as one of the most basic sequential logic circuit possible. This simple flip-flop is basically a one-bit memory bistable device that has two inputs, one which will "SET" the device (meaning the output = "1"), and is labelled S and another which will "RESET" the device (meaning the output = "0"), labelled R.

Then the SR description stands for "Set-Reset". The reset input resets the flip-flop back to its original state with an output Q that will be either at a logic level "1" or logic "0" depending upon this set/reset condition.

A basic NAND gate SR flip-flop circuit provides feedback from both of its outputs back to its opposing inputs and is commonly used in memory circuits to store a single data bit. Then the SR flip-flop actually has three inputs, Set, Reset and its current output Q relating to its current state or

history. The term “Flip-flop” relates to the actual operation of the device, as it can be “flipped” into one logic Set state or “flopped” back into the opposing logic Reset state.

The NAND Gate SR Flip-Flop

The simplest way to make any basic single bit set-reset SR flip-flop is to connect together a pair of cross-coupled 2-input NAND gates as shown, to form a Set-Reset Bistable also known as an active LOW SR NAND Gate Latch, so that there is feedback from each output to one of the other NAND gate inputs. This device consists of two inputs, one called the *Set*, S and the other called the *Reset*, R with two corresponding outputs Q and its inverse or complement Q (not-Q) as shown below.

The Basic SR Flip-flop

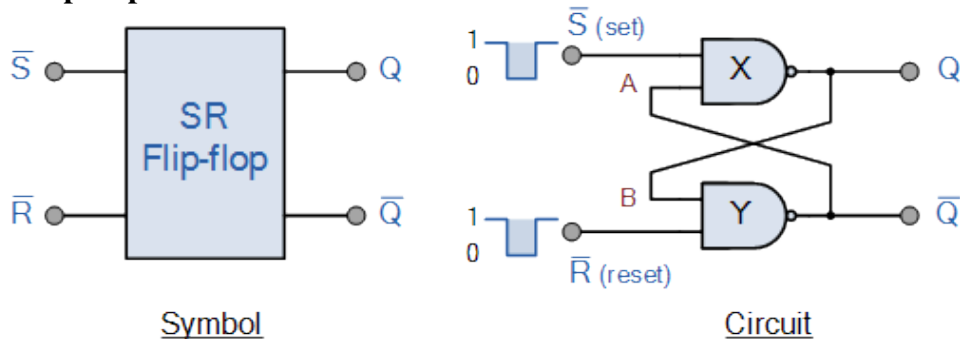

The Set State

Consider the circuit shown above. If the input R is at logic level “0” ($R = 0$) and input S is at logic level “1” ($S = 1$), the NAND gate Y has at least one of its inputs at logic “0” therefore, its output Q must be at a logic level “1” (NAND Gate principles). Output Q is also fed back to input “A” and so both inputs to NAND gate X are at logic level “1”, and therefore its output Q must be at logic level “0”.

Again NAND gate principals. If the reset input R changes state, and goes HIGH to logic “1” with S remaining HIGH also at logic level “1”, NAND gate Y inputs are now $R = “1”$ and $B = “0”$. Since one of its inputs is still at logic level “0” the output at Q still remains HIGH at logic level “1” and there is no change of state. Therefore, the flip-flop circuit is said to be “Latched” or “Set” with $Q = “1”$ and $Q = “0”$.

Reset State

In this second stable state, Q is at logic level “0”, ($Q = “0”$) its inverse output at Q is at logic level “1”, ($Q = “1”$), and is given by $R = “1”$ and $S = “0”$. As gate X has one of its inputs at logic “0” its output Q must equal logic level “1” (again NAND gate principles). Output Q is fed back to input “B”, so both inputs to NAND gate Y are at logic “1”, therefore, $Q = “0”$.

If the set input, S now changes state to logic “1” with input R remaining at logic “1”, output Q still remains LOW at logic level “0” and there is no change of state. Therefore, the flip-flop circuits “Reset” state has also been latched and we can define this “set/reset” action in the following truth table.

Truth Table for this Set-Reset Function

State	S	R	Q	Q	Description
Set	1	0	0	1	Set $Q \gg 1$
	1	1	0	1	no change
Reset	0	1	1	0	Reset $Q \gg 0$
	1	1	1	0	no change
Invalid	0	0	1	1	Invalid Condition

It can be seen that when both inputs $S = “1”$ and $R = “1”$ the outputs Q and Q can be at either logic level “1” or “0”, depending upon the state of the inputs S or R BEFORE this input condition existed. Therefore the condition of $S = R = “1”$ does not change the state of the outputs Q and Q.

However, the input state of $S = “0”$ and $R = “0”$ is an undesirable or invalid condition and must be avoided. The condition of $S = R = “0”$ causes both outputs Q and Q to be HIGH together at logic level “1” when we would normally want Q to be the inverse of Q. The result is that the flip-flop loses control of Q and Q, and if the two inputs are now switched “HIGH” again after this condition

to logic “1”, the flip-flop becomes unstable and switches to an unknown data state based upon the unbalance as shown in the following switching diagram.

S-R Flip-flop Switching Diagram

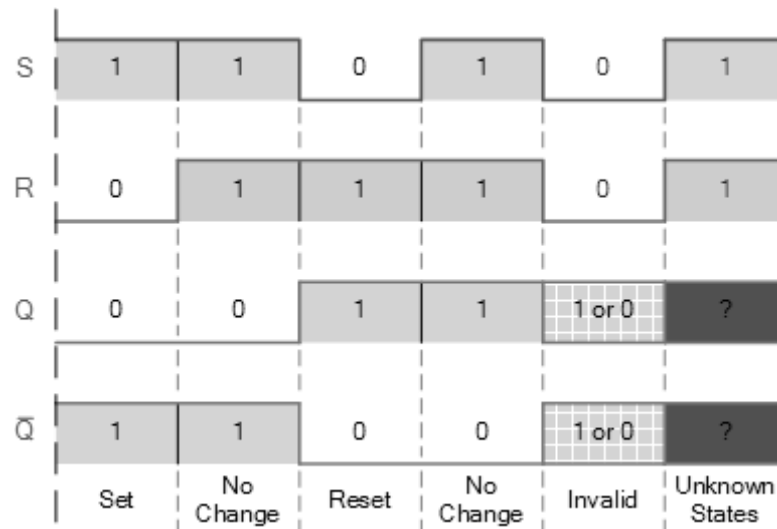

This unbalance can cause one of the outputs to switch faster than the other resulting in the flip-flop switching to one state or the other which may not be the required state and data corruption will exist. This unstable condition is generally known as its **Meta-stable** state.

Then, a simple NAND gate SR flip-flop or NAND gate SR latch can be set by applying a logic “0”, (LOW) condition to its Set input and reset again by then applying a logic “0” to its Reset input. The SR flip-flop is said to be in an “invalid” condition (Meta-stable) if both the set and reset inputs are activated simultaneously.

As we have seen above, the basic NAND gate SR flip-flop requires logic “0” inputs to flip or change state from Q to \bar{Q} and vice versa. We can however, change this basic flip-flop circuit to one that changes state by the application of positive going input signals with the addition of two extra NAND gates connected as inverters to the S and R inputs as shown.

Positive NAND Gate SR Flip-flop

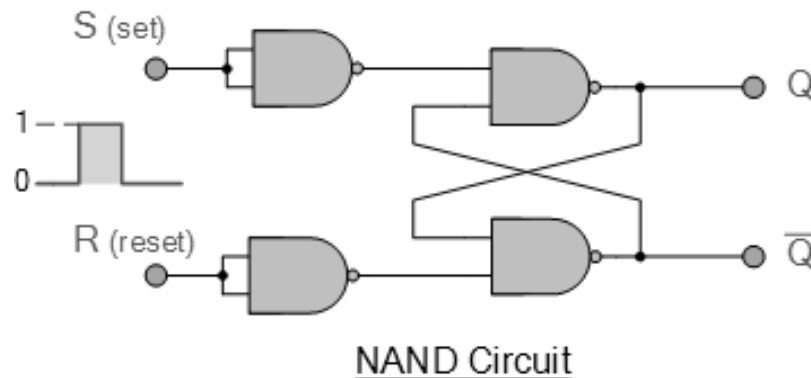

S	R	Q	\bar{Q}
0	0	No change	
0	1	0	1
1	0	1	0
1	1	X	X
(Invalid)			

18	Diagonalization by Jacobi’s Method	PHY09
-----------	---	--------------

1. What do you mean by diagonalization of a matrix?
2. What is symmetric matrix?
3. What is eigen value and eigen function?
4. What is transpose of a matrix?

GENERAL ELECTRICAL AND ELECTRONIC TERMS

ELECTRONIC COMPONENTS

What are the basic components of any electronic circuit?

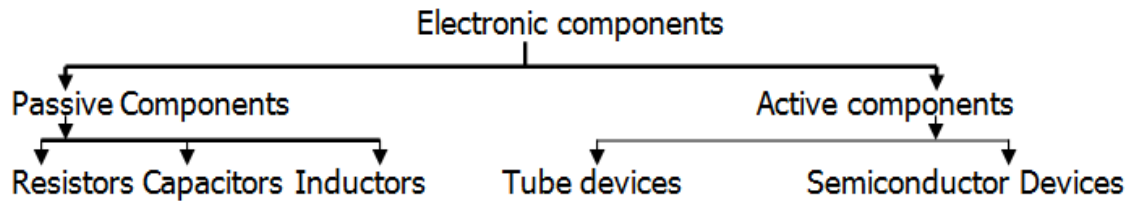

Define Passive Components?

The components of the circuit, which are not capable of amplifying or processing electrical signals by themselves. e.g. Resistors, Capacitors and Inductors

What are active components in a circuit?

The components of the circuit which can process or amplify the input signal are called active components.

ACTIVE COMPONENTS

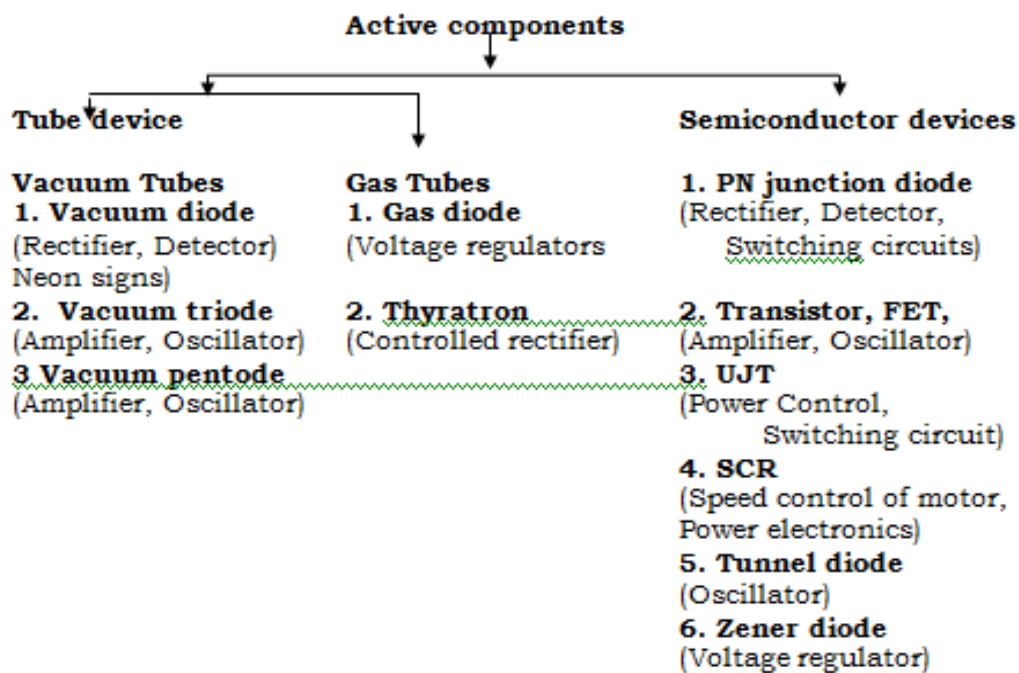

SEMICONDUCTOR PHYSICS

What is a semiconductor?

A semiconductor is a solid material whose electrical resistivity is higher than that of a conductor and lower than that of an insulator.

What are the characteristic of semiconductors?

- The electrical resistivity of a semiconductor is higher than that of a conductor and lower than that of an insulator.
- The electrical resistance of a semiconductor decreases with increase in temperature over a particular temperature range.
- The electrical conductivity of a semiconductor can be increased by a large value by addition of a small amount of suitable impurity.
-

QUESTIONS BANK

SEMICONDUCTOR PHYSICS

1. Name at least two conductors, two insulators and two semiconductors? Give the order of conductivities of these materials.
2. Define intrinsic and extrinsic semiconductors?
3. Define doping.
4. Define N-type semiconductor (donor type semiconductor).
5. Define P-type semiconductor (acceptor-type semiconductor).
6. Explain what is a hole?
7. Explain why pentavalent impurity atom is known as donor-type impurity?
8. Explain why trivalent impurity atom is known as acceptor-type impurity?

CONDUCTION IN SEMICONDUCTORS

1. In pure (intrinsic) semiconductor, explain the mechanism of conduction by electrons and holes.
2. Explain the Fermi level in a semiconductor having impurities.
3. With the help of energy band structure, explain the insulator, semiconductor and insulator.
4. Distinguish between p and n type of semiconductor through energy band diagram, clearly showing energy gap and Fermi level.
5. What is the purpose of doping in a semiconductor? How does it change the characteristics of semiconductor?
6. Explain the significance of diffusion current in semiconductor?
7. What is meant by the potential barrier across a junction? What is its significance?

PN JUNCTION DIODE

1. What do you mean by a p-n junction diode?
2. Draw the symbol of p-n junction diode.
3. What is a depletion layer?
4. Explain how depletion layer is formed?
5. Draw the circuit showing forward biasing of p-n junction diode.
6. Draw the circuit showing reverse biasing of p-n junction diode.
7. Explain the action of pn junction under forward bias.
8. Explain the action of pn junction under reverse bias.
9. Why a junction diode offers very high resistance in reverse biased mode?
10. Why a junction diode offers very low resistance in forward biased mode?
11. What are the applications of PN junction diode?
12. Explain V-I Characteristics of a P-N diode.
13. Define i) Static Characteristic, ii) Dynamic Characteristics. iii) Transfer Characteristics.
14. State the applications of diodes.
15. Define Breakdown voltage.
16. Define the terms (a) Maximum power current and (b) Peak Inverse Voltage (PIV).

BIPOLAR JUNCTION TRANSISTOR

1. Draw the symbols of pnp and npn Transistors.
2. Explain the functions of emitter, base and collector.
3. Show by means of a diagram, how you normally connect external batteries in pnp /npn transistor.
4. Explain the action of pnp/npn transistor with neat diagram.
5. Enlist the three transistor configurations. [CE/CB/CC]
6. Define the parameters α and β . Show that it is always less than unity. Obtain the relation between them.

TRANSISTOR BIASING

1. State different methods of biasing.

2. For a self bias circuit, derive an expression for the stability factor S.
3. Explain fixed biasing in case of pnp/npn transistor. Draw the necessary diagram.
7. State the advantages and disadvantages of fixed biasing method of a transistor.
8. What do you understand by stabilization of operating point?
9. Define stability factor.
4. Discuss the causes for bias instability in a transistor
5. Define Q-point. Explain how it is established in emitter bias circuit?
6. What is stability factor? Discuss the three stability factor associated with instability of collector current.
7. Discuss the two biasing circuit used in Linear integrated circuit. Bring out their merits and demerits.
8. Why biasing is needed for transistor? State the requirements of biasing circuit.
9. Which two points are necessary to draw the dc load line?
10. What is the utility of dc load line?
11. Explain Q point on load line. Write a note on operating point.
12. Draw the (i) Input (ii) Output (iii) Transfer characteristics of a transistor.

TRANSISTOR AMPLIFIERS

1. What do you mean by an amplifier?
2. What are coupling capacitor and why are they required?
3. Define current gain and voltage gain.
4. Draw the frequency response characteristics of an amplifier.
5. Define cutoff frequencies. Define bandwidth of an amplifier.
6. What should be the input resistance of an ideal amplifier? Why?
7. What should be the output resistance of an ideal amplifier? Why?
8. Describe the conversion efficiency of an ideal amplifier.
9. Explain how the operating point is located for CE amplifier.
10. What are the different classes of amplifier?
11. What is a load line and operating point?
12. Discuss graphical method for the working of a transistor amplifier in CE mode.
13. Discuss advantages of graphical method.

CONCEPT OF FEEDBACK

1. What do you mean by feedback in amplifiers?
2. State the types of feedback.
3. State the advantages of negative feedback.
4. State clearly the difference between the regenerative and degenerative feedback.
5. Discuss the general characteristics of negative feedback.
6. Derive an expression for the input resistance of voltage series feedback topology.
7. Draw a feedback amplifier in block diagram form. Identify each block and explain its function.
8. With a neat sketch, describe the concept of feedback in amplifier.
9. What is the effect of Feedback on Input impedance, Output impedance, band width.

TRANSISTOR AT LOW FREQUENCY

1. Obtain Hybrid parameter model of a transistor.
2. What are the advantages of using hybrid model to represent the transistor?
3. Explain how the h-parameters can be obtain from the static characteristics of the transistor.
4. Draw the hybrid model of a transistor & explain the significance of each element.
5. Obtain h-parameter model of a transistor.
6. Explain the method of obtaining base voltage, base current, collector voltage & collector current wave form using graphical analyses.
7. What are the advantages of h-parameters.

TRANSISTOR AT HIGH FREQUENCY

1. Derive expression for transistor conductance g_m and conductance $g_{b'e}$.
2. Derive expression for transistor input conductance $g_{b'e}$ and feedback conductance $g_{b'c}$

MULTISTAGE AMPLIFIER

3. Explain different types of distortions in amplifier.
4. How are amplifiers classified? Discuss them briefly.
5. Classify the various transistor amplifiers.

OSCILLATORS

1. Explain the working of an oscillator? Oscillators
2. Explain Barkhausen's criterion for self sustained oscillations.
3. Which basic principle is used in LC Tank circuit oscillator? Explain why LC circuit is called as a Tank circuit.
4. What is the main advantage of using CE amplifier?
5. State and explain the condition for sustained oscillation.
6. Why LC Tank circuit is called an oscillator?
7. With the help of neat diagram, explain the working of small signal single stage RC coupled CE amplifier.
8. Describe the Hartley oscillator. Obtain the resonant frequency of Hartley oscillator
9. Distinguish LC Tank circuit oscillator and Hartley oscillator.

LOGIC GATES

1. Define Logic gate. Explain with examples positive and negative logic.
2. Enlist the basic Logic gates.
3. Give the symbol and logical expression of AND/OR/NOT/NAND/NOR/Ex-OR gate. Write truth table of each.
4. State De-Morgan's first theorem. State De-Morgan's second theorem.
5. What do you mean by Flip-Flops? State the types of Flip-Flops.
6. Explain construction of AND/OR/NOT/NAND/NOR/Ex-OR gate.
7. Explain the working of R-S FF, J-K FF, D FF.
8. Explain why NAND/NOR gate is called as universal building block.

OPERATIONAL-AMPLIFIER

1. What is differential amplifier?
2. List the characteristics of an ideal Op-amp.
3. Define the terms wrt OP-AMP: CMRR (ii) PSRR (iii) output offset voltage (iv) Slew rate (v) input bias current.
4. With the necessary circuit diagram, explain the measurement of A_v , R_o , V_{ios} , input offset current, CMRR, Slew rate of an Op-amp and explain.
5. Explain how to measure the differential input resistance R_i of an Op-amp.
6. Explain the significance of virtual ground in an Op-amp circuit.
7. Describe a method of measuring CMRR of an Op-amp.
8. List characteristics of an ideal op amp.
9. Draw the circuits of inverting amplifier and non- inverting amplifiers. Obtain the output expression for voltage gain.
10. Explain how op-amp can be configured as an adder and integrator? Obtain the output expressions for both.
11. Explain an op-amp follower. What are its special features and where it is used?
12. Show how op-amp can be used as subtractor. Obtain an expression for its output.

Basic Text & Reference Books :-

Advanced Practical Physics for students

B L Wosnop and H T Flint, Methuen and Co. Ltd., London

B.Sc. Practical Physics

C L Arora, S.Chand & Co. Ltd., New Delhi

Advanced Practical Physics

M S Chauhan and S P Singh, Pragati Prakashan, Meerut

Advanced Practical Physics

S L Gupta and V Kumar, Pragati Prakashan, Meerut

An advanced course in Practical Physics

D Chattopadhyay and P C Rakshit, New Central book agency Pvt. Ltd.